



**IRON FIREMAN®**

## **WhirlPower™ Gas-Oil Burners**

### **Model G-120 Forced Draft Commercial Gas-Oil Burners**

#### **Features**

The WhirlPower™ G-120 Gas-Oil Burners are complete fuel burning systems, assembled, wired and tested at the factory. The units have all necessary operating controls including an electronic combustion control system. All air for combustion is supplied under pressure by the forced draft fan.

The Gas-Oil Burners are particularly applicable to installations in localities where standby oil heating equipment is required. Quick changeover is accomplished by a fuel selection switch; it is not necessary to alter or readjust the burner.

Model G-120 Burners are constructed with the fan housing below the draft tube with no burner parts projecting above the draft tube to interfere with boiler cleanout doors. This compact arrangement makes these models particularly adaptable to Scotch-Marine type boilers.

Oil only burners are equipped with direct oil-electric spark ignition with a 10,000 volt transformer.

Gas and Gas/Oil burners are equipped with a 6,000 volt transformer and gas electric for gas pilot when firing either gas or oil as main fuel. (Internal Pilot).

Burners are listed by Underwriters' Laboratories, Inc., to operate with not heavier than No. 2 fuel oil, as specified in U.S. Commercial Specifications for Fuel Oils CS 12 and Natural or L.P. Gases. Models also available to comply with FM and IRI requirements.

Models available for firing rate of 600,000 Btu to 3,000,000 Btu input for gas and 7 to 21.5 GPH for oil.

High resistance firing head mixes air and fuel instantly giving short clean flame with complete combustion.

No refractories necessary to assist combustion.

Eliminates need for draft producing or chimney induced draft fan when boiler is sealed because burner fan handles pressure drop across boiler as well as burner.

Frees burner performance of deficiencies due to erratic or excessive overfire draft.

Provides a high degree of reliability and efficiency of operation in conventional unsealed steel and cast iron boilers by permitting installation through fire door with only refractory floor at mud ring level.

Cuts to negligible amount stand by loss during "off" periods, by conduction and convection to cooler masonry or air and eliminates heat robbing cold air flow because of extremely small air passages in burner head.

#### **When Ordering Specify:**

- 1. The Boiler Make and Model Number.**
- 2. Steam Pressure or Water Temperature.**
- 3. Insurance Approval Required (UL, FM or IRI).**
- 4. Burner Model.**
- 5. Firing Rate-GPH Light Oil or MBh Gas.**
- 6. Electrical Characteristics for Blower Motor and Control Circuit.**
- 7. Gas Type, Btu/cf and Gas Pressure.**

*Catalog information subject to change without notice.*

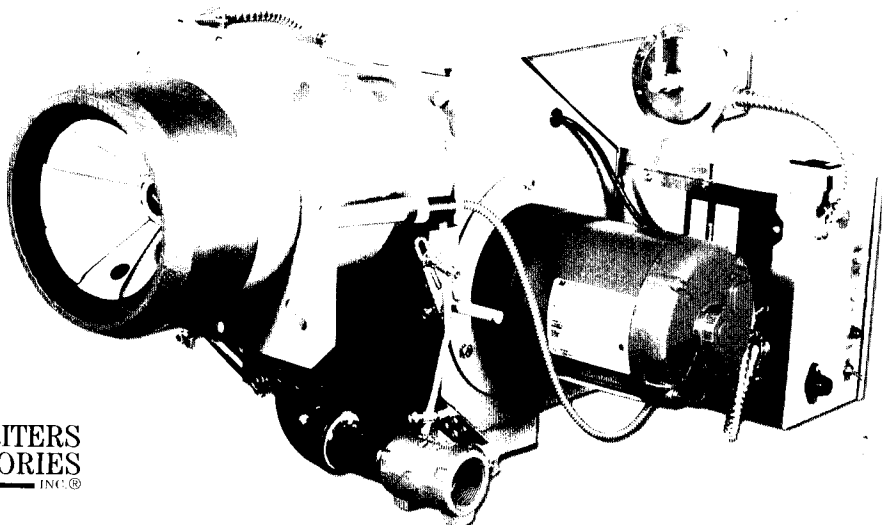



# IRON FIREMAN®

## WhirlPower™

### Model G-120 Forced Draft Commercial Gas-Oil Burners

#### U.L. Models

Cat. No.	Model	Fuel(s)	Motor HP	Max. Firing Rate @ .5" wc Fur. Press.	Weight
90353004	G-120-G-1.4	Gas	1/2	1400MBH	100
90353005	G-120-G-2.1		3/4	2100MBH	105
90353006	G-120-G-3.0		1	3000MBH**	110
90353007	G-120-GO-1.4	Gas/#2	1/2	1400MBH/10-GPH	110
90353008	G-120-GO-2.1		1	2100MBH/15GPH	115
90353009	G-120-GO-3.0		1	3000MBH/21.5GPH**	120
90353001	G-120-O-1.4	Oil	1/2	10GPH	80
90353002	G-120-O-2.1		1	15GPH	85
90353003	G-120-O-3.0		1	21.5GPH	90

\*\* High Gas Switch furnished for firing rates over 2499 MBH.

#### Standard Equipment

##### General

Proven Flame Retention Head Design  
 Forward Curved Blower  
 Flame Observation Port  
 Firing Head Access Cover  
 Forced Draft Fan Motor 115-60-1  
 On-Off Switch  
 Air Flow Safety Switch

##### Gas

Air Flow Safety Switch  
 Fireeye Flame Safeguard  
 U.V. Flame Scanner  
 Gas Pilot Ignition  
 Spud Type Gas Mixing System  
 Fixed Fire Operation on 1.4  
 Low-High-Off Operation on 2.1 and 3.0

##### Oil

Direct Spark Ignition  
 Integral Two Stage Fuel Pump  
 Simplex Oil Nozzle  
 Fireeye Flame Safeguard  
 U.V. Flame Scanner  
 Low Fire Start Firing Operation  
 Main Oil Solenoid Valve 1.4 and 2.1 Models  
 Dual Main Oil Solenoid Valves 3.0 Model

##### Gas/Oil Combination

Fireeye Flame Safeguard  
 U.V. Flame Scanner  
 Gas Pilot Ignition  
 Spud Type Gas Mixing System  
 Manual Fuel Selector Switch  
 Integral Two Stage Fuel Oil Pump  
 Simplex Oil Nozzle  
 On-Off Firing Operation with 1.4  
 Low Fire Start Firing Operation with 2.1 and 3.0

#### Optional Equipment

FM (High Risk)  
 I.R.I.  
 Low Fire Start  
 Low-High-Low Modulation  
 Microprocessor Controls  
 Remote Panels  
 Gas Control Groups  
 Oversize Panels

## **Suggested Specifications For Iron Fireman "WhirlPower™" C-120 Gas/Oil Packaged Burner**

Furnish and install as shown on plans \_\_\_\_\_ Iron Fireman "WhirlPower™" packaged gas/#2 oil burner(s), model number G-120. Each burner(s) shall be capable of burning \_\_\_\_\_ cfh of \_\_\_\_\_ Bth/cu. ft. (natural) (L.P.) (Manufactured) gas at a specific gravity of \_\_\_\_\_ with minimum gas pressure of \_\_\_\_\_ inches water column and/or maximum of \_\_\_\_\_ inches at inlet to burners' gas piping group; and \_\_\_\_\_ gph of No. 2 fuel oil.

Electrical current will be available in the boiler room at \_\_\_\_\_ volts \_\_\_\_\_ cycle \_\_\_\_\_ phase. Blower motor to be no smaller than \_\_\_\_\_ horsepower and 3450 RPM.

The complete burner shall be listed with Underwriters' Laboratories and be forced draft type, factory assembled, wired, and factory firetested. Equipment to include direct driven blower that supplies combustion air and forces products of combustion thru boiler and stack, totally enclosed hinged 14 gauge metal electrical control cabinet, containing a \_\_\_\_\_ combustion safeguard control system with integral pre-purge, motor starter or relay, control circuit reducing transformer to 115 volts (when motor exceeds 115 volts), manual on-off switch, numbered terminal strips, separate oil and gas indicating signal lights, ignition light, flame failure light, flame observation port with glass. (control circuit fuse when motor exceeds 115 volts) internal access, and manual fuel selector switch.

Upon interruption of electrical power, the burner shall recycle before fuel valve(s). opens; and upon flame failure, the electronic

combustion control shall lockout and require manual reset. Burner motor shall not run during "lockout" condition. For dependability, the air flow safety switch is to be of the differential pressure sensing type.

The main fuel oil or gas is to be ignited by an internal gas pilot that includes a 6000 volt secondary transformer, manual gas cock, gas pressure regulator and solenoid valve. Ignition to be of the interrupted type. (Oil Only Burners shall be direct spark ignited by a 10,000 volt transformer.)

Oil burning equipment to include two-stage integral fuel oil pump, oil filter, instantaneous cut-off oil valve, low fire start with varying oil pressure from 125 to 300 psi.

Gas burning equipment shall include a completely piped gas train, including manual gas cock, gas pressure regulator, gas valve(s), safety gas solenoid valve and gas pressure gauge. The iron pipe size shall be not less than \_\_\_\_\_ inches.

A safety limit control is to be furnished by burner supplier. The control is to be suitable for \_\_\_\_\_ psi steam (or \_\_\_\_\_ °F water temperature).

Each control cabinet is to contain a wiring diagram, installation, operation, maintenance, service instructions, and replacement parts manual; factory firetest report indicating actual factory firetest results, input, CO<sub>2</sub>, smoke reading, pressure reading, and flame signal.

### **Optional Equipment at Extra Trade Price**

Additional Signal Lights	Remote Main Panels
Alarms	Operating Control
Gas Piping Group	Limit Control
Duel Ignition Kits	Modulation Control
Microprocessor Flame Safeguard and Annunciator Systems	

## Dimensions

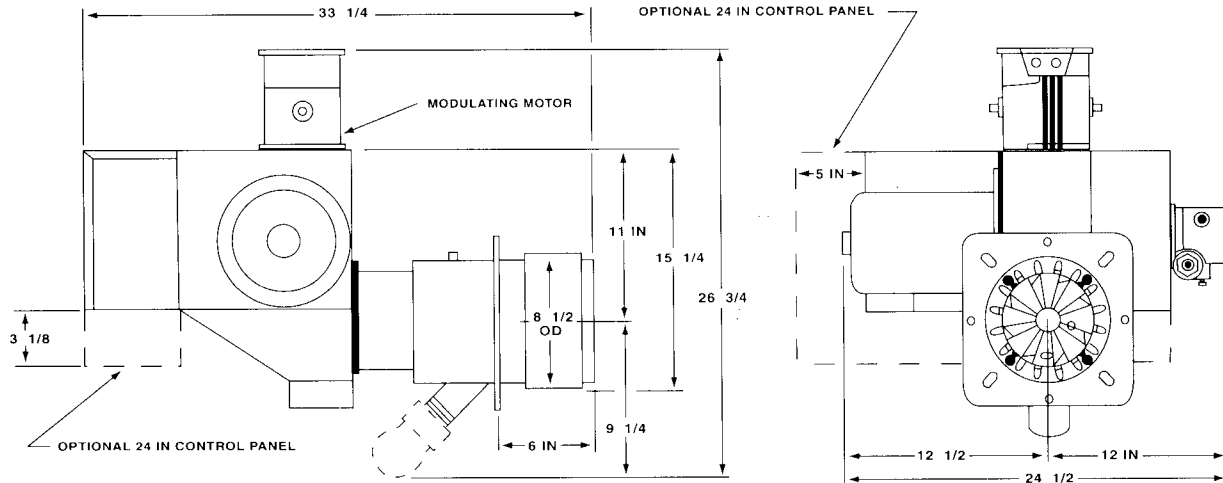

G120 "Upright" Models

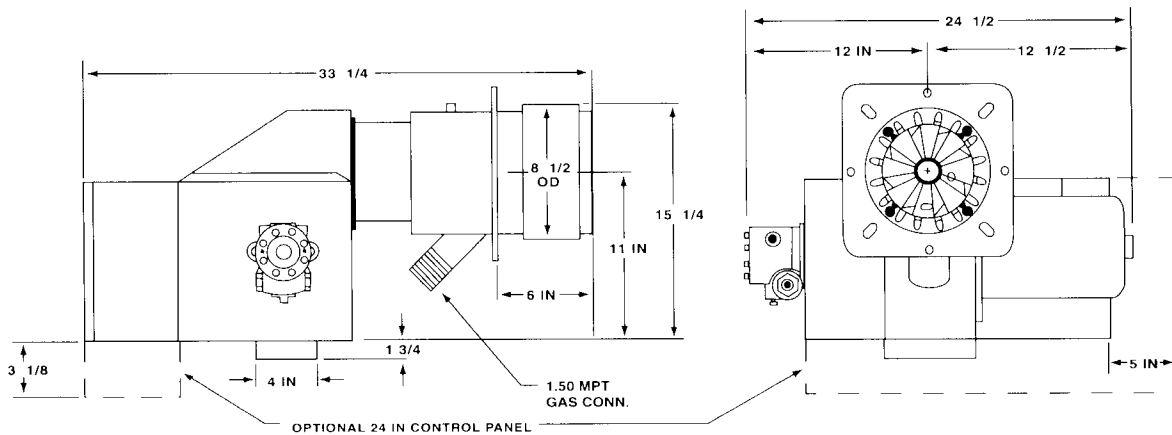

G120 "SM" Models

## Burner Mounting Details

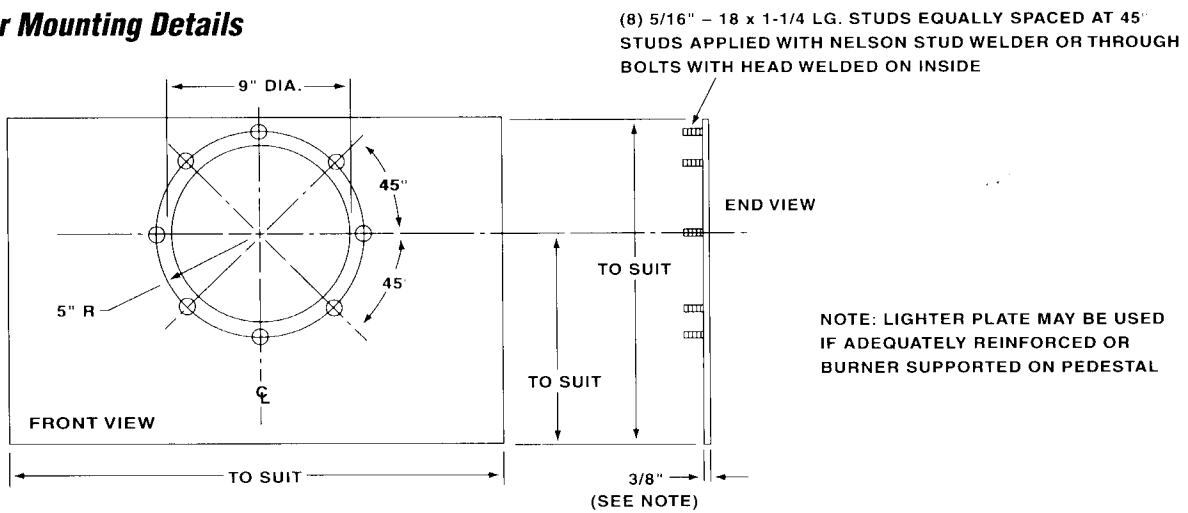

**IRON FIREMAN**®

551 S. County Line Rd. • Franklin Park, IL 60131-1013 • Ph: 630.694.5500  
Fax: 630.694.2230 • www.vaporpower.com • www.ironfireman.com

Form No. 80-2021F  
Printed in U.S.A.  
6/03